

## AV BOXES

FOR WALL. BUILT IN.

TB W INS

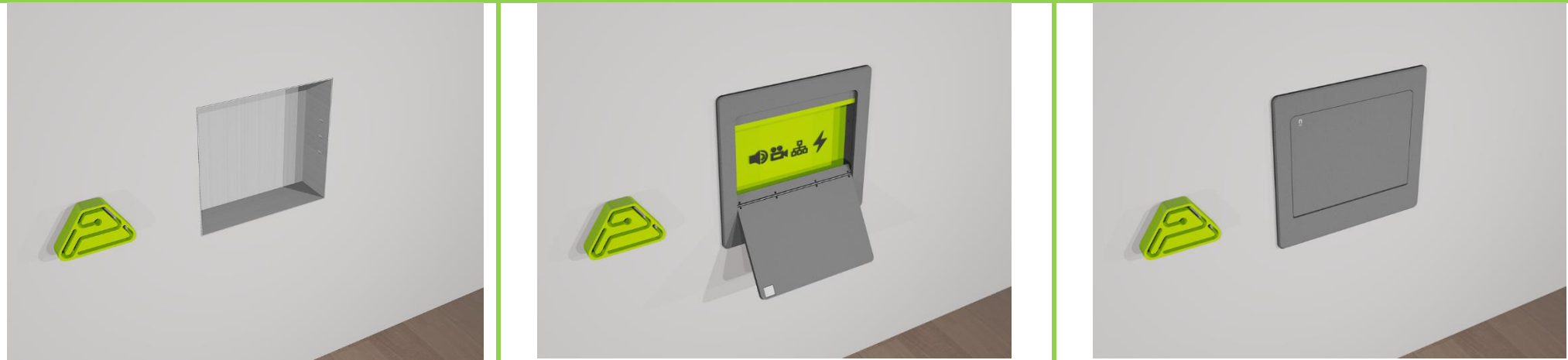

- Door with **push opening**.
- **Galvanized back box** to build in wall
- They are **boxes to be recessed in the wall**, by means of a galvanized back box and receive on site or be screwed into plasterboard.
- **Full customization of the box** in terms of connectors, texts, logos and colour, allowing full integration with the aesthetics of the room.
- **Designed and manufactured by Pinanson S.L. in Spain**

## Applications

- Room where is required to have access to video, audio, data and power connections in a box recessed in the wall
- Facilities in which keeping the boxes integrated with the decoration of the room as well as high durability are important factors.

## Special Characteristics

- **Box with door** to protect the connectors
- Door with **push opening** to be opened by hand pression
- **Galvanized back box** to receive on site
- **Perpendicular** connection to the wall
- **Custom manufacturing:** connectors, color, according to the room aesthetics, texts, logos

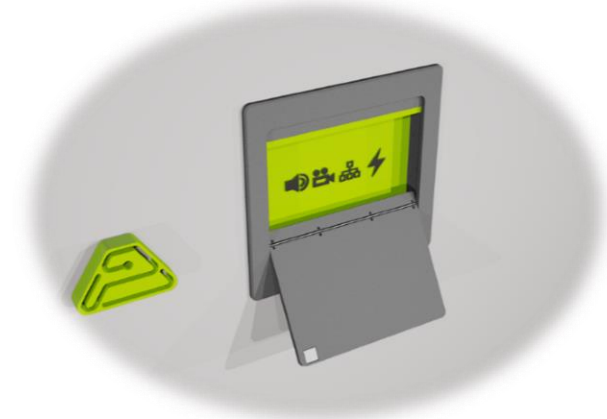

Push opening

Models

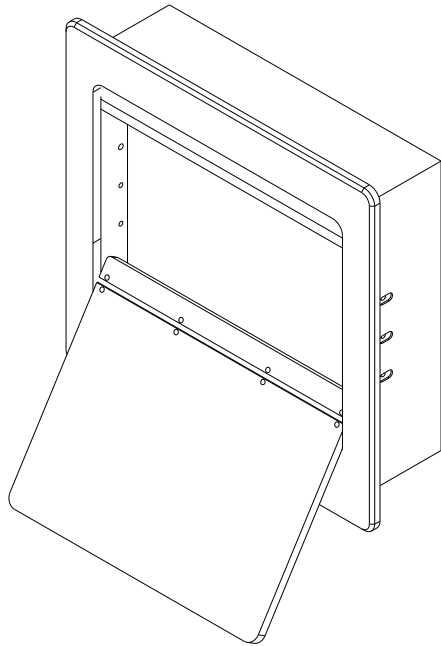

TB W INS

Dimensions

230 x 230 x 100/200

Gap

205 x 190 mm

## Physical Characteristics

	MATERIAL							GROSOR		
	Extruded aluminium	Aluminium plate	6063 Alloy	Treatment T5	Stainless steel	Galvanised steel	Nickel-plated brass	1.5mm	3 mm	6 mm
Panel Frame										
Top and bottom panel										
Door and Flap										
Union laterals										
Door axis										
Back box										
Axis support										
General finish	PAINT		COLOR		TEXTS					
	Powder electrostatic covering		Under request		Direct printing of logos, texts according client preferences					



## Mechanical Characteristics

Approx. weight

1.5 Kg



Web: [www.pinanson.eu](http://www.pinanson.eu)  
@: [pinanson@pinanson.eu](mailto:pinanson@pinanson.eu)

PINANSON S.L  
Avda. Constitución, 40. Mondéjar (Guadalajara). ESPAÑA.  
Teléfono: +34 949 385 444 · Fax: +34 949 385 643

**Revisión: December 2020**

For possible changes due to continuous product improvements; Pinanson S.L. reserves the right to change the showed data in this document without notice. The data presented here correspond to the time it was compiled.